



For low drain / long term operating applications requesting good voltage response in  $-40^{\circ}\text{C}\sim+125^{\circ}\text{C}$  environments, such as TPMS(Tire Pressure Monitor System).

International size reference: 1/6D .

## Electrical characteristics

(Typical values for cells stored for one year or less, at  $25^{\circ}\text{C}$ )

● <b>Nominal capacity</b>		1.4Ah
(At 1.0mA, $+25^{\circ}\text{C}$ , 2.0V cut off. The capacity restored by the cell varies according to current drain, temperature and cut off voltage.)		
● <b>Rated voltage</b>		3.6V
● <b>Maximum recommended continuous current</b>		10mA
(To get 50% of the nominal capacity at $+25^{\circ}\text{C}$ with 2.0V cut off. Higher currents possible, consult EVE.)		
● <b>Maximum pulse current capability</b>		50mA
● <b>Rated 1 sec.pulse capability(to 3V)</b>		20mA
<b>Pulse capability</b> varies according to pulse characteristics (frequency duration), temperature, cell history (storage conditions prior to usage) and the application' s acceptable minimum voltage.		
● <b>Storage</b>	(recommended)	$30^{\circ}\text{C}$ max
	(possible without leakage)	$-55^{\circ}\text{C}\sim+120^{\circ}\text{C}$
● <b>Operating temperature range</b>		$-40^{\circ}\text{C}\sim+125^{\circ}\text{C}$
(Operation at temperature different from ambient may lead to reduced capacity and lower voltage plateau readings.)		
● <b>Typical weight</b>		24g

### ⚠ WARNING:

Fire, explosion and severe burn hazard. Do not recharge, crush, disassemble, heat above  $150^{\circ}\text{C}$ , incinerate, or expose contents to water. Do not solder directly to the cell.

## ER32L100T

Lithium-thionyl Chloride  
(Li-SOCl<sub>2</sub>) Battery

### KEY FEATURES

- ✓ High and stable operating voltage
- ✓ High minimum voltage during pulsing
- ✓ Low self discharge rate (less than 1% after 1 year of storage at  $+25^{\circ}\text{C}$ )
- ✓ Stainless steel container
- ✓ Hermetic glass-to-metal sealing
- ✓ Non-flammable electrolyte
- ✓ Compliant with IEC 86-4 safety standard and EN 50020 intrinsic safety
- ✓ Non restricted for transport
- ⚠ Underwriters Laboratories (UL) component Recognition (File Number MH 28717)

### MAIN APPLICATIONS

- ✓ Tire Pressure Monitor System
- ✓ Alarms and security devices
- ✓ Memory back-up
- ✓ Tracking systems
- ✓ Automotive electronics
- ✓ Professional electronics ... etc.

Note: Any representations in this brochure concerning performance, are for informational purposes only and are not construed as warranties either expressed or implied, of future performance.

## 1. DISCHARGE CHARACTERISTICS@+25°C

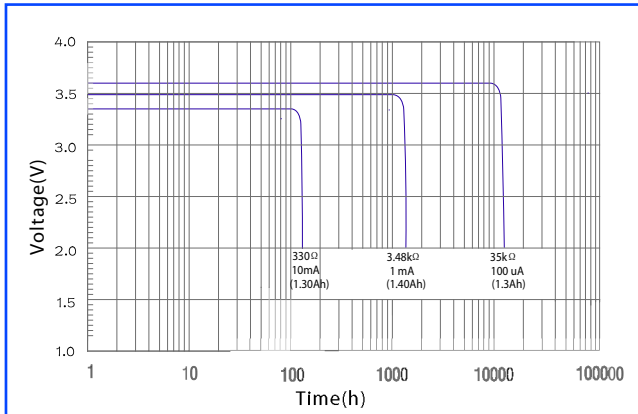

# ER32L100T

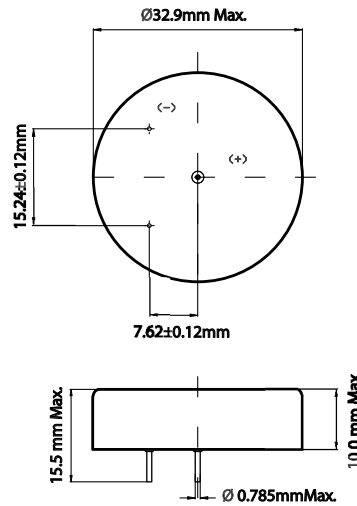

## 2. VOLTAGE VS. TEMPERATURE

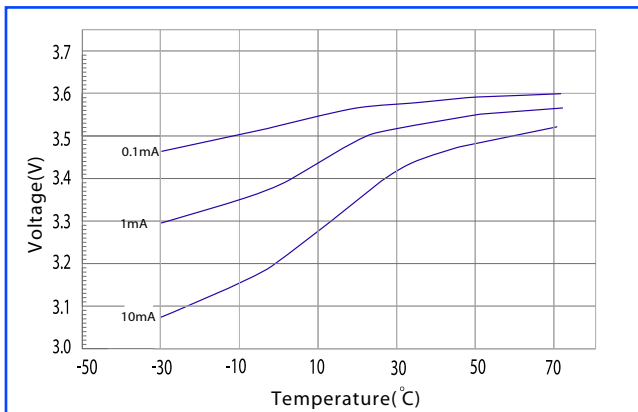

### AVAILABLE TERMINATIONS:

Suffix -P Tinned Nickel Pins

## 3. CAPACITY VS. CURRENT

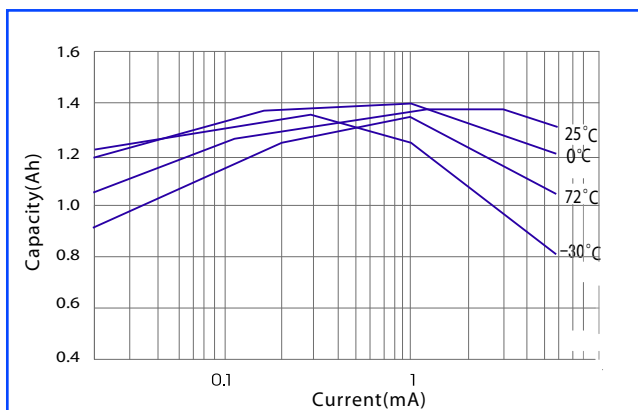

## 4. STORAGE CHARACTERISTICS

